

# AUSTRALIAN NATIVE BEE HIVE

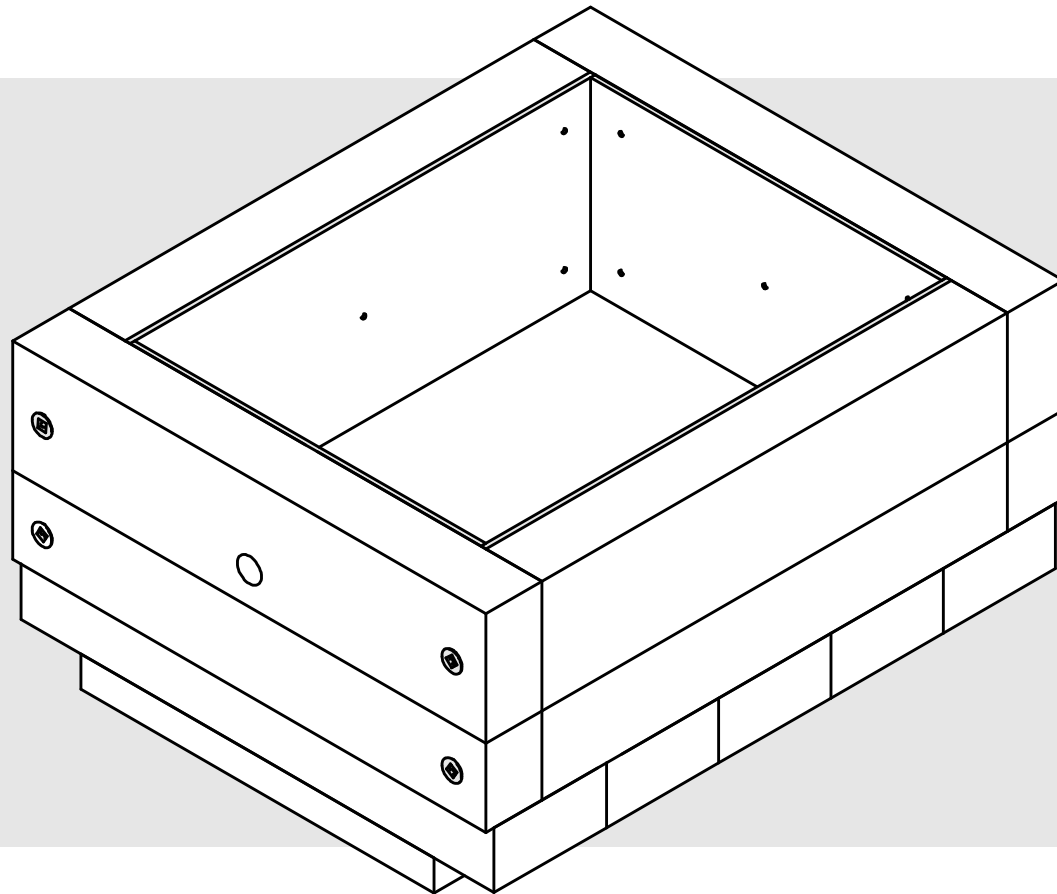

## Retrofit Hive - Construction and Assembly



# Exploded View

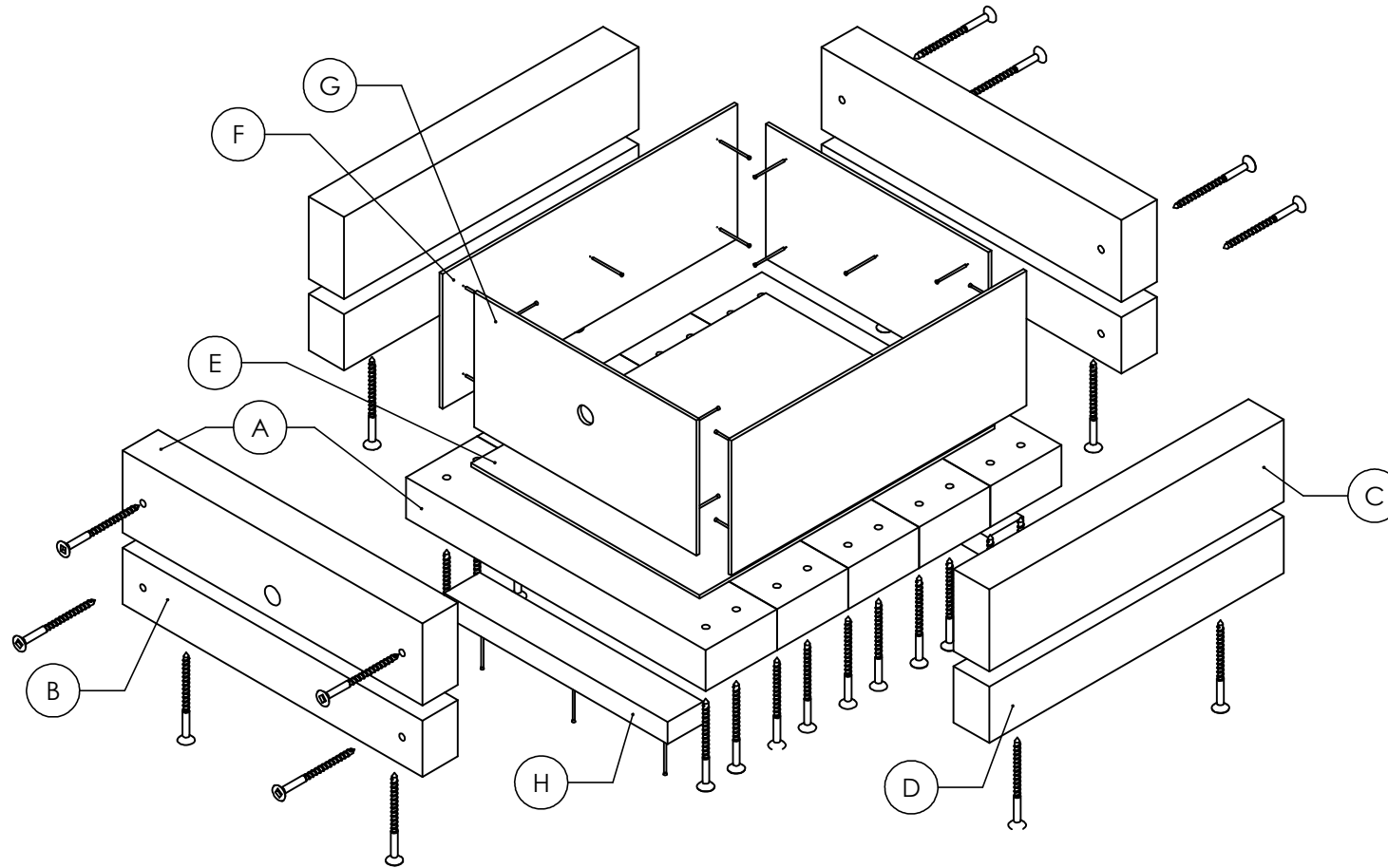

# Components

2x Timber frame front and rear - upper

5x Timber base assembly

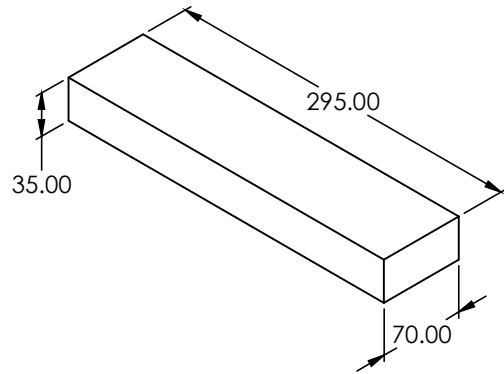

**A**

2x Timber frame front and rear - lower

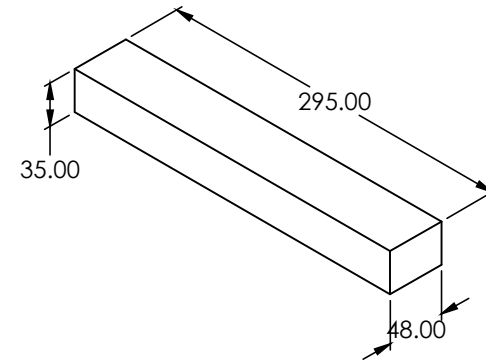

**B**

2x Timber frame sides - upper

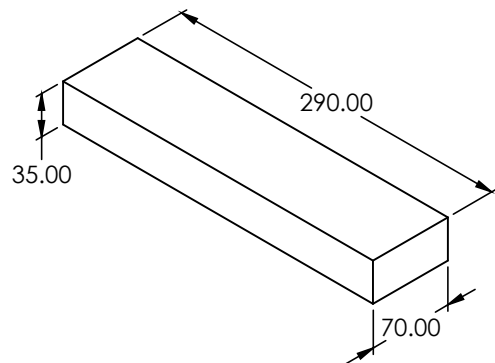

**C**

2x Timber frame sides - lower

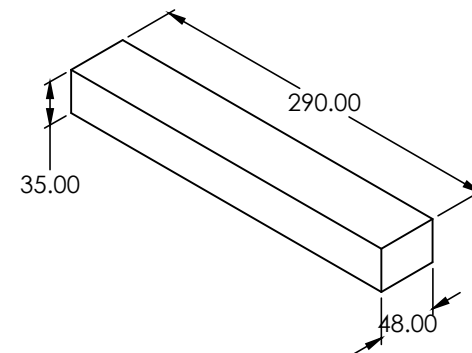

**D**

# Components

1x Plywood inner base lining

**E**

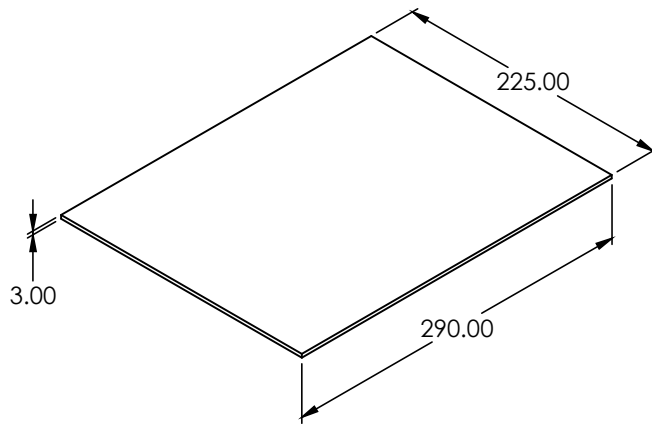

2x Plywood inner side wall lining

**F**

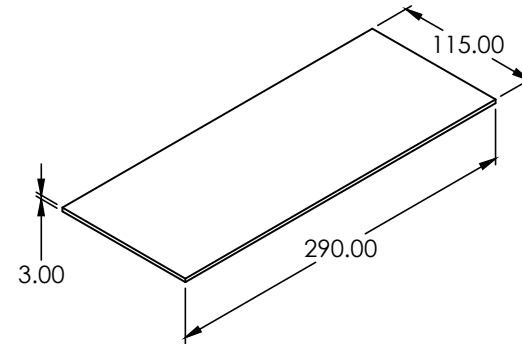

2x Plywood inner front and rear wall lining

**G**

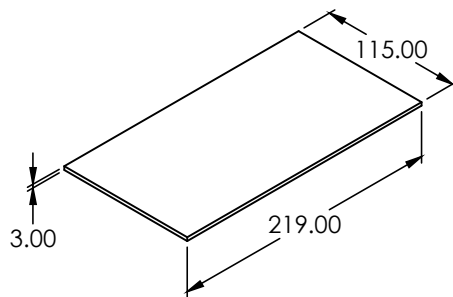

2x Timber feet

**H**

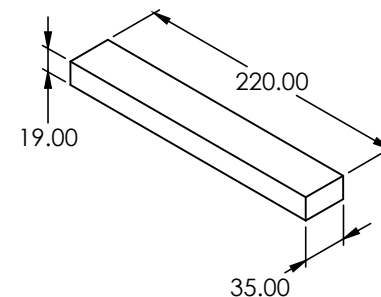

# Components

---

**36x**      Screws (10-8 x 75 countersunk rib head square drive galvanised)



**25x**      Nails (30 x 1.6 bullet head)



# 1

## Frame Assembly SECTION 1 of 2

Drill 5.50mm pilot holes positioned as shown in the dimensional diagram through both part A & B lengths of timber.

The pilot holes through the wider faces of parts A & B will be used later in Step 3.

Position parts A & B of the frame as shown. Push the screws through the pilot holes on the narrow face of parts B and screw into parts A.

Ensure parts A and B are flush with their adjoining faces.

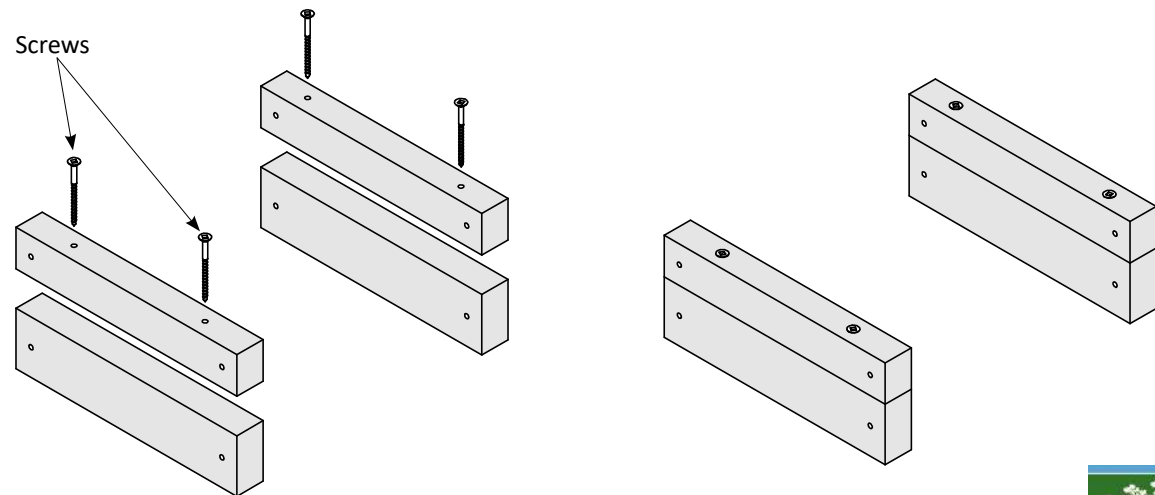
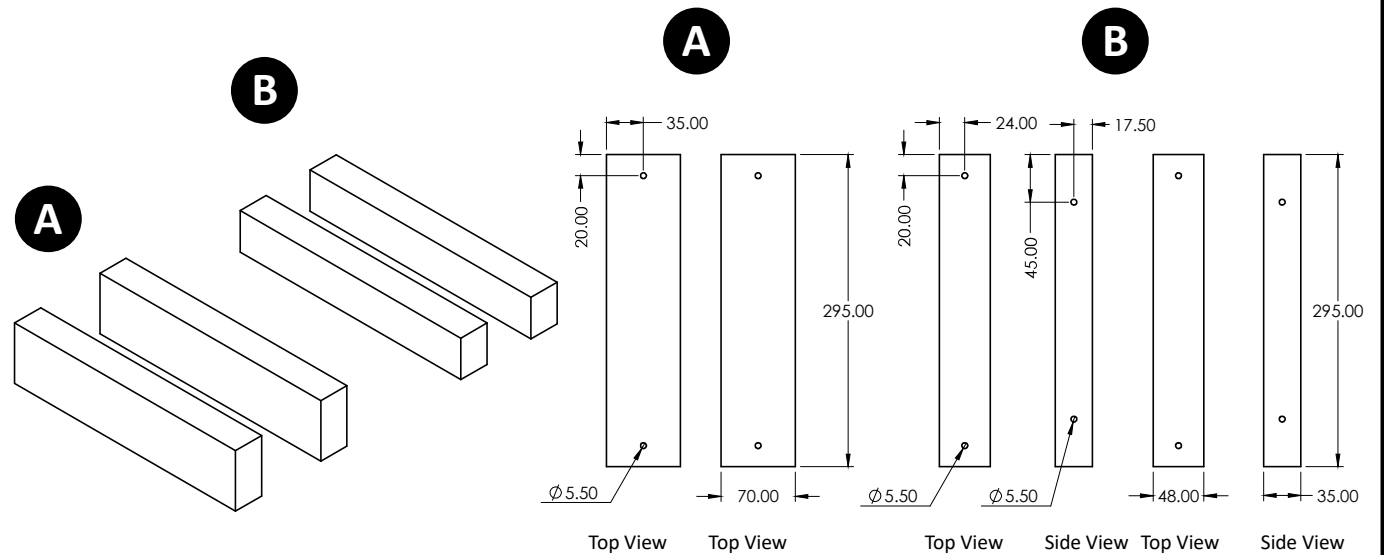

# 2

## Frame Assembly SECTION 2 of 2

Drill 5.50mm pilot holes positioned as shown in the dimensional diagram through part D lengths of timber.  
Position parts C & D of the frame as shown.  
Push the screws through the pilot holes of parts D and screw into parts C.  
Ensure parts C and D are flush with their adjoining faces.

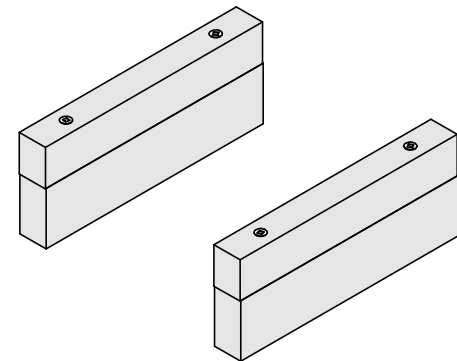
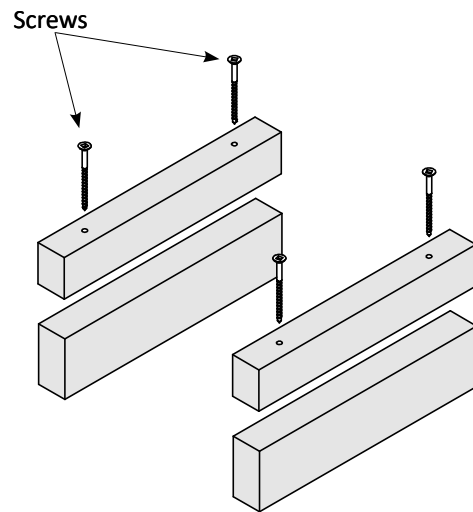
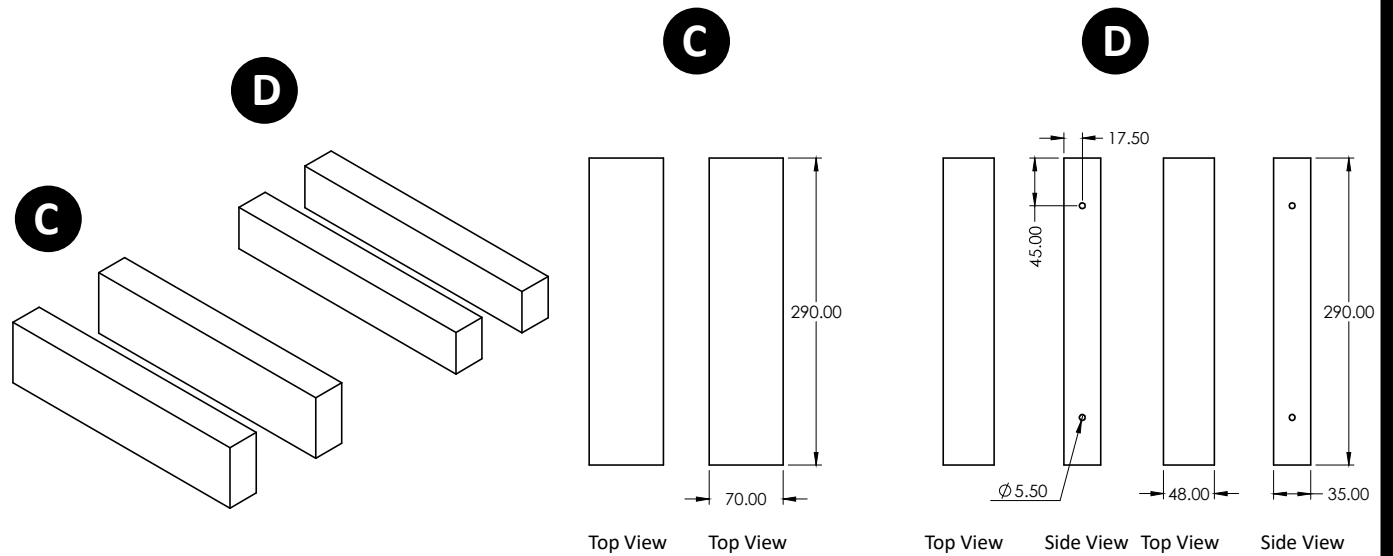

# 3

## Frame Assembly

### JOIN SECTIONS 1 and 2

Drill 5.50mm pilot holes positioned as shown in the dimensional diagram through Section 1.

Position Sections 1 and 2 perpendicular to each other as shown. Push the screws through the pilot holes of Section 1 and screw into Section 2.

Ensure Sections 1 and 2 are positioned flush with their adjoining faces.

#### SECTION 1

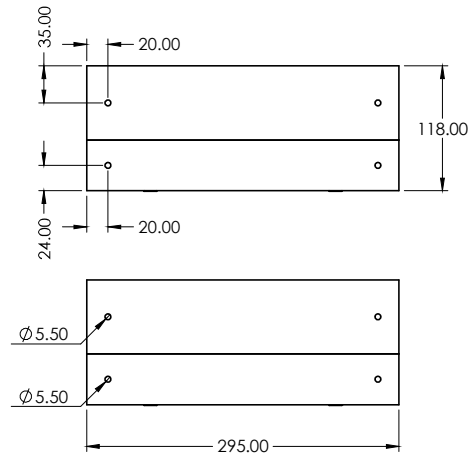

#### SECTION 2

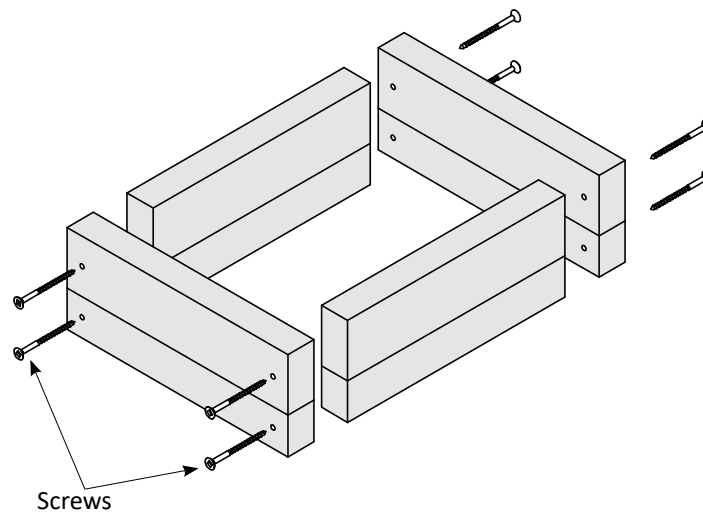
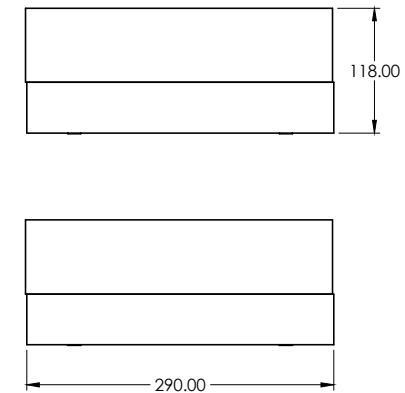



# 4

## Base Assembly

Drill 5.50mm pilot holes positioned as shown in the dimensional diagram through four part A lengths of timber.

Position parts A on the frame and push the screws through the pilot holes and screw into the frame.

Ensure the first piece of timber is aligned flush with the frame before screwing into position. The remaining four pieces of timber can then butt against each preceding piece before screwing into position.

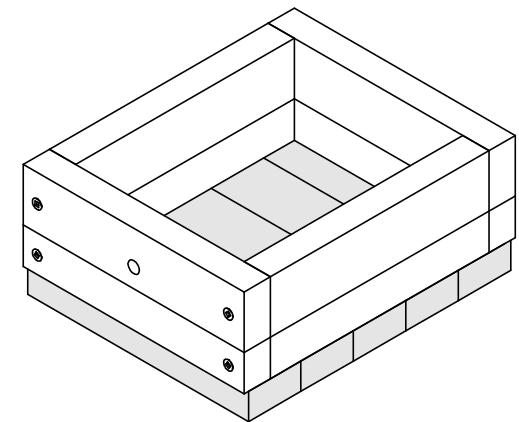
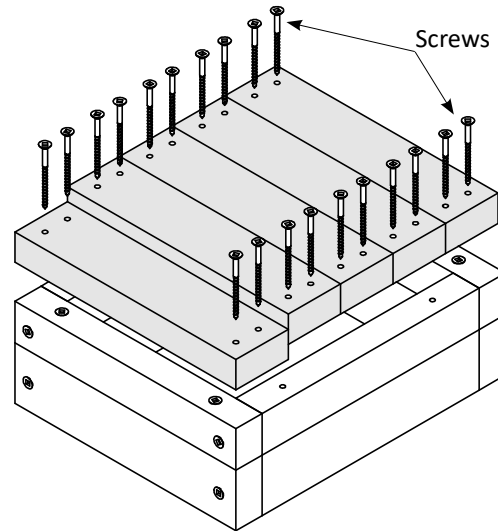
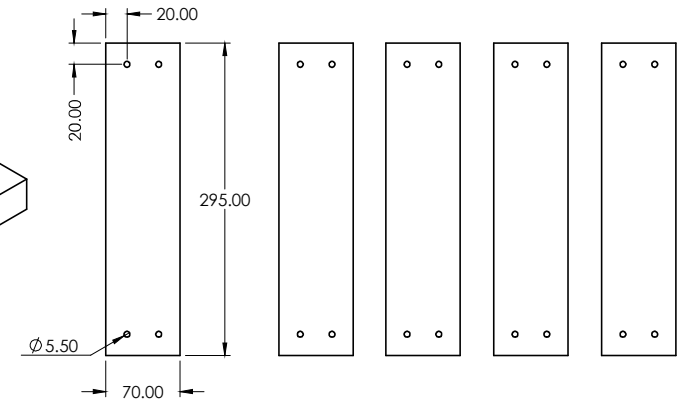
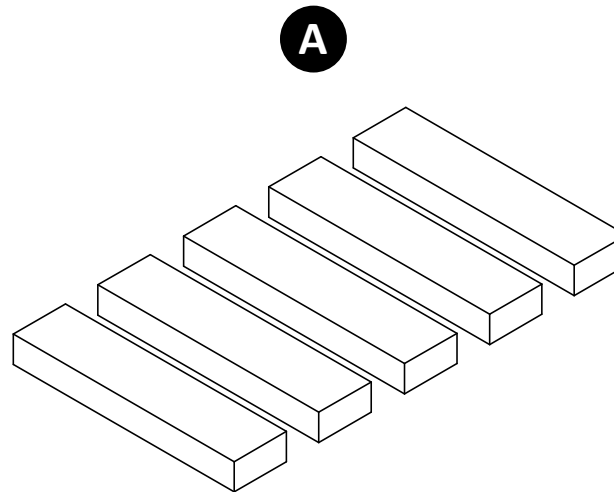

# 5

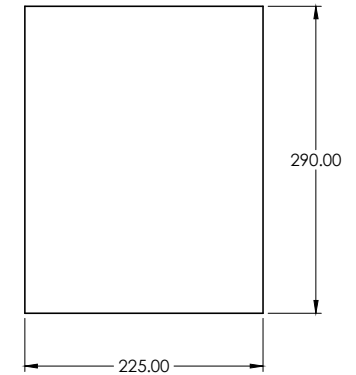
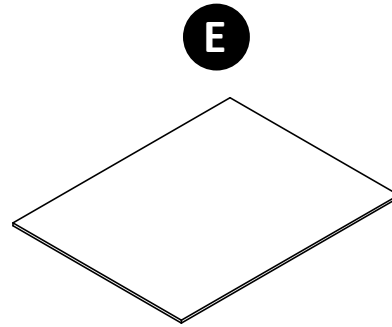

## Plywood Base Lining

Position the plywood base lining into the frame assembly so that it is flush with the base.

No gluing or fastening is required as the inner plywood wall lining assembled in Steps 6 and 7 will hold it in place.

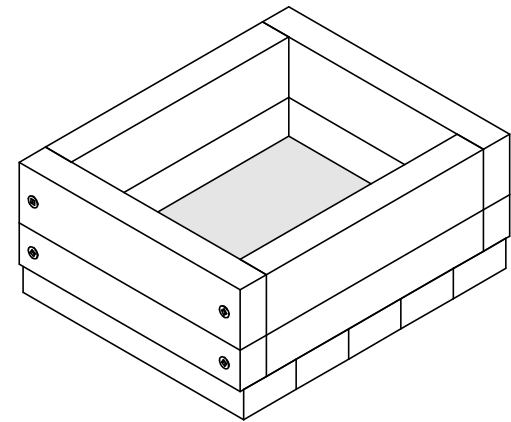
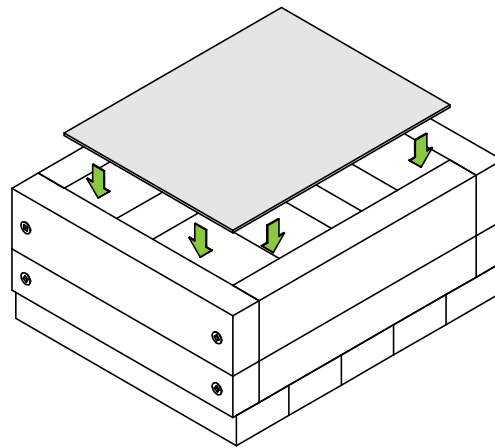

# 6

## Plywood Wall Lining

### STEP 1 of 2

Position parts F of the inner wall lining so that they are flush with the plywood base lining and butt against the walls of the frame assembly as shown.

The two pieces of plywood can then be secured by nailing them in position. Five nails, two on either end and one in the middle should suffice. The nails can be roughly positioned as indicated in the diagram.

F

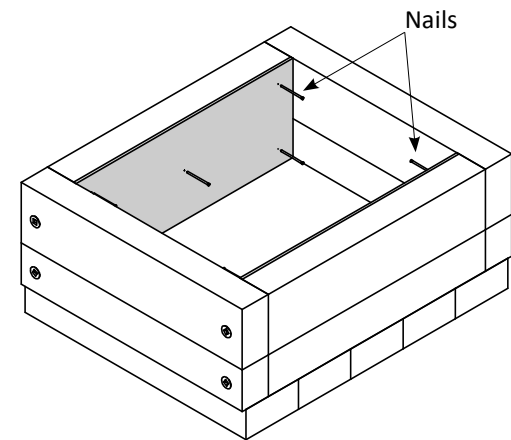
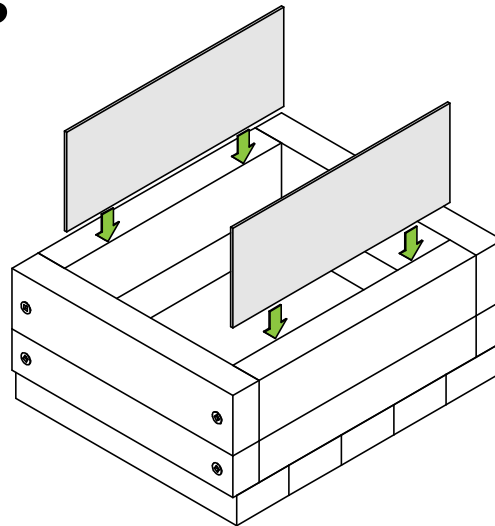
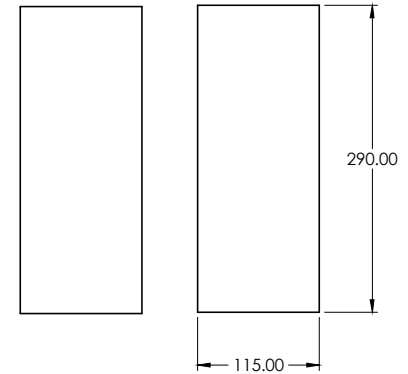
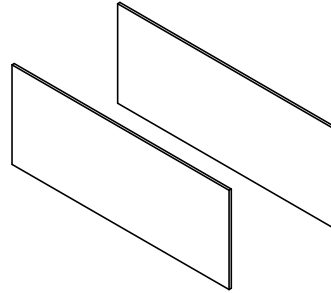

# 7

G

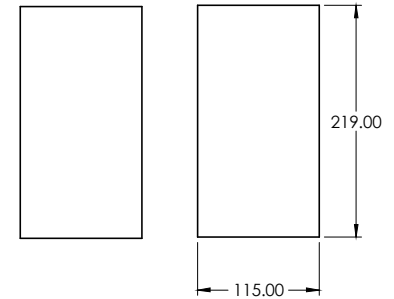
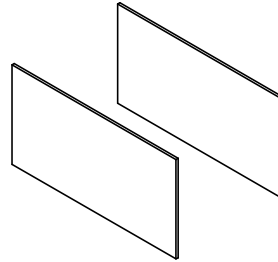

## Plywood Wall Lining STEP 2 of 2

Position parts F of the inner wall lining so that they are flush with the plywood base lining and butt against the walls of the frame assembly as shown. The two pieces of plywood can then be secured by nailing them in position similar to the previous step.

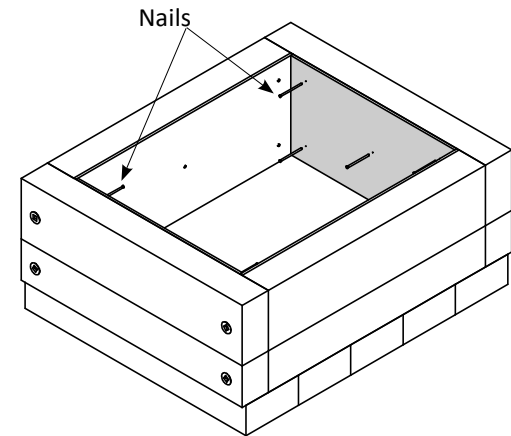
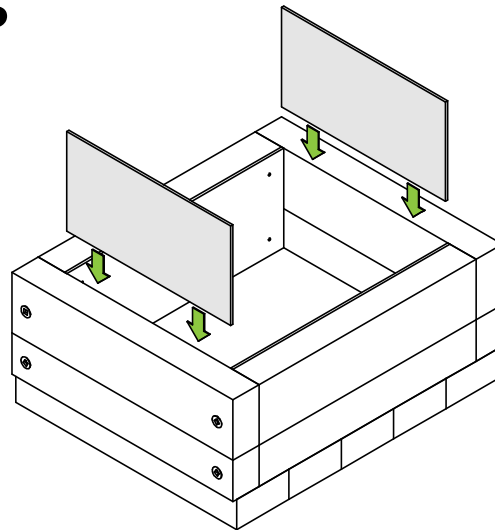

# 8

## Optional Step PLANE SURFACES

Depending on the grade of timber one uses, there is the possibility that once constructed the top of the hive half i.e. the plane that will come in contact with the other hive half when assembled, may not be level across all 4 sides. This can happen with many untreated timbers where there can be a few millimetres error in sizing. It is important not to ignore this, as this causes gapping, making your hive vulnerable.

Using a wood planer, gently plane down those parts that stand proud until they are level with the rest of the box. Equally, a belt sander or bench-mounted circular saw could also work to trim the top of the box.

Surfaces to Plane

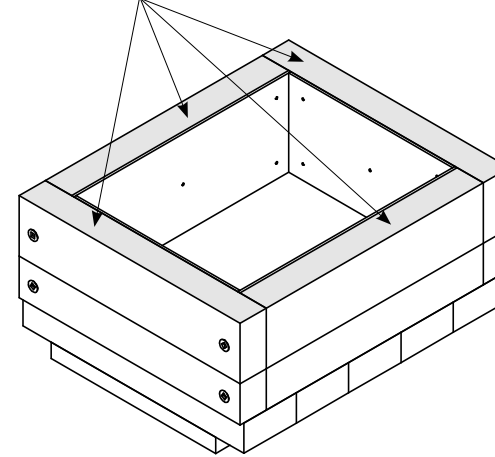

Level with No Gaps between Top & Bottom Half of Hive

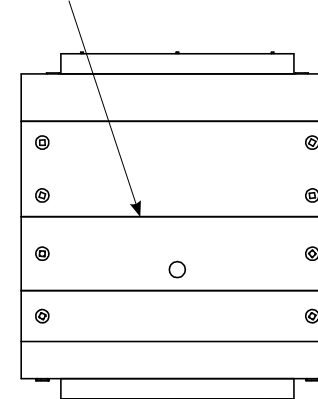

**ASSEMBLED HIVE**

# 9

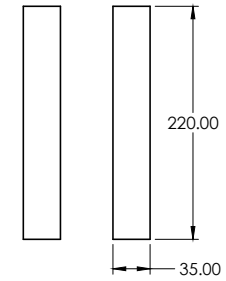
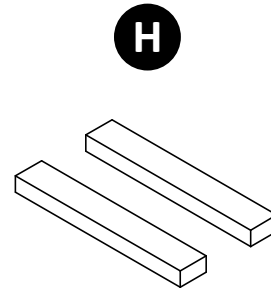

## Attach Feet

Position and align the feet so they are flush with the front and rear face of the base as shown.

Secure the feet in position with three nails for each foot.

### NOTE:

If the specified standard timber is not available from your supplier, off-cuts can be used as a substitute.

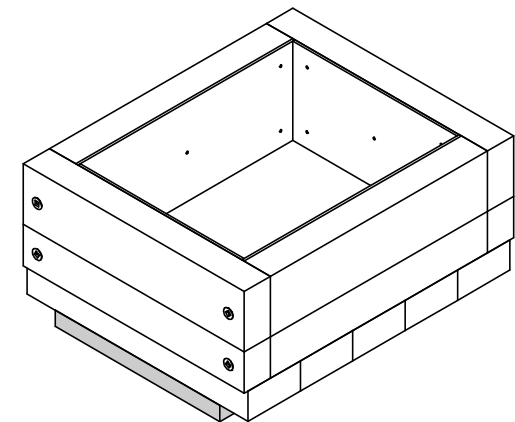
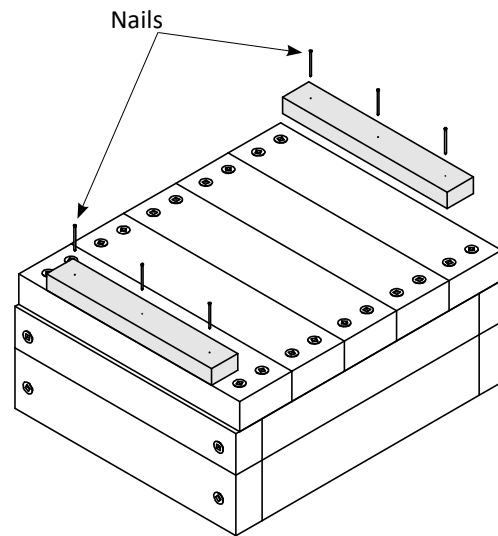

# 10

## Entrance Hole

Drill a 15mm hole through one side of the hive positioned as shown according to the dimensionial drawing and passing through both the outer and inner walls of the hive.

**NOTE:**

When drilling the hole from the outside in, support the thin plywood lining with a small block of timber or similar. This will help hold the plywood against the hive wall and prevent the plywood coming away from the main frame whilst drilling.

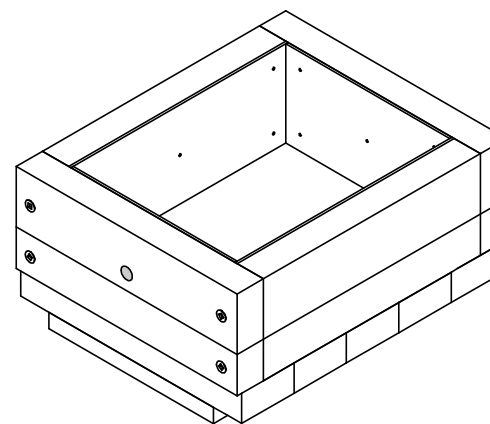
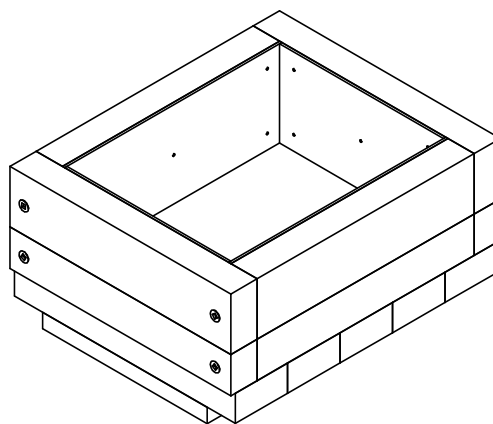
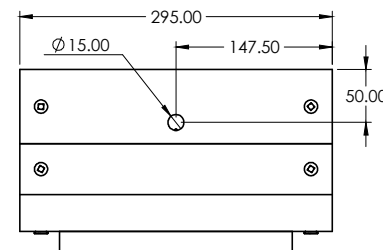

# 11



## Paint or Stain

Apply an external, water-based paint or stain to your hive according to the manufacturer's instructions. Many external paints are self-priming so can be applied directly to the box. Apply a second coat if needed. Paint all external faces of the hive but do not paint the inside of the hive. Leave a 5mm ribbon of unpainted wood around the outside edge of the inner plywood lining. Please refer to the 'Ku-ring-gai Stingless Beehive Box Schematics – Supporting Information' for more information on painting/staining your hive.



**PAINTED HIVE**



# 12

## Retrofitting a Hive

1. Assess whether the hive is ready to split (weight & activity).
2. Remove polystyrene casing without breaking if possible.
3. Clean the outside of the OATH hive of any lumps of resin or honey pots that may have formed in the void between the OATH and the polystyrene.
4. Split hive as usual.
5. Reassess whether hive should remain split – brood levels, food stores - Reassemble if the hive is not ready (this is why keeping the poly box intact is useful).
6. Clean up any spilled contents.
7. Place each half of the OATH into a retro box, ensuring that entrances align.
8. Place an empty KOATH half on each retro box and seal with masking tape.
9. Split complete.

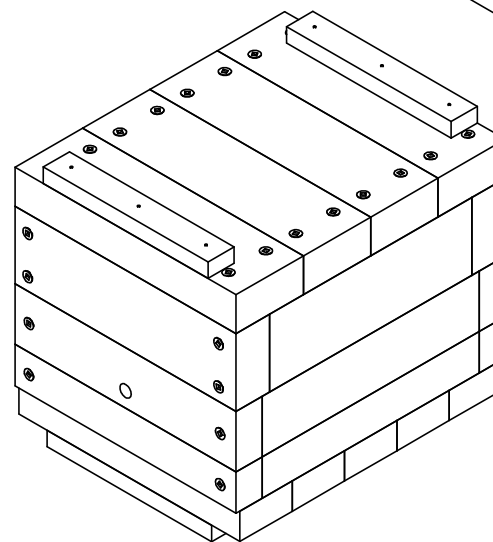
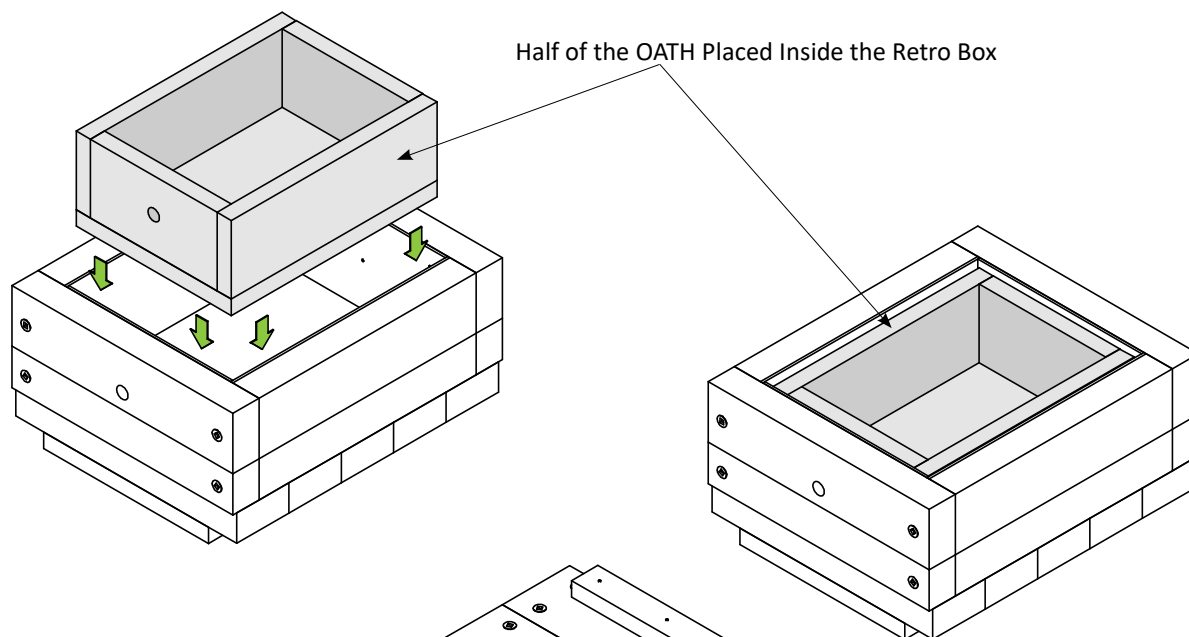

**ASSEMBLED HIVE**



AUSTRALIAN NATIVE BEE HIVE  
Retrofit Hive  
Construction and Assembly

Revision: 10